



ix Teco® (7TE) half cylinder

SKU DO.ix7TE.HZ.333HB
Producer No. 333HBix7TE

System ix Teco® (7TE) „Easy access to superior security“

The new ix Teco® reversible key (commercial profile ix 7TE) is particularly well protected against unauthorized copying by an innovative additional stamped recess in the key, based on a patented technology. A special high-low (HT) milling technology in the horizontal base profile increases security during profile control and is difficult to copy. With the innovative and sophisticated design, you acquire a locking system with efficient key copy protection, which is predestined for use in the locking system, but also for individual locks.

Basic length

- from 30,5/10 mm
- measured from the middle of cam
- extension in 5 mm steps
- from 75,5/10 mm, the production is carried out in modular design

Technical characteristics

- high protection against manipulation due to 20-fold locking authorisation query
- anti bumping (impact key protection) & anti picking pins (picking protection)
- up to 12 horizontal and vertical profile control pins: control points for the authorization query of a key
- 7 spring-loaded pin locking elements, axially arranged, made of special brass/hardened steel offer manipulation protection (6 variable tumblers, 1 function pin interrogation for the stamped recess)
- 12 core and body pins
- narrowed core and body pins for safety during scanning and unlocking
- drilling protection (standard): 2 hardened steel pins in the body, 1 hardened steel pin in the cylinder core
- 13 mm core diameter
- one-piece cam made of sintered steel
- concave core head as key insertion aid
- according to DIN EN 1303:2015-08, certified according to ISO 9001:2015
- locking security class 6, attack resistance class B (locking system class C) according to DIN EN 1303
- patent protection until 2038

Execution

- cylinder body and cylinder core made of solid brass (high corrosion protection)
- finish: dull nickel
- reversible key system
- horizontal key insertion
- cam 8-fold adjustable
- compatible with DOM electronics (made possible by integrating passive transponder technology into the key bow via a clip tag)

Options / special equipment

- modular design with increased tear-off protection (through hardened steel bar) *
- different cylinder finishes **
- increased drilling protection **
- weather protection **
- freewheel **

Operational area

- for single- or multi-turn mortise locks and various other locks
- switch cylinder for elevator technology, garage doors, key switches, activation devices, roller shutters (with side mounting), apartment buildings, larger residential areas
- small and medium commercial objects

Scope of delivery

- half cylinder incl. 3 or more keys
- 1 fixing screw
- Security card

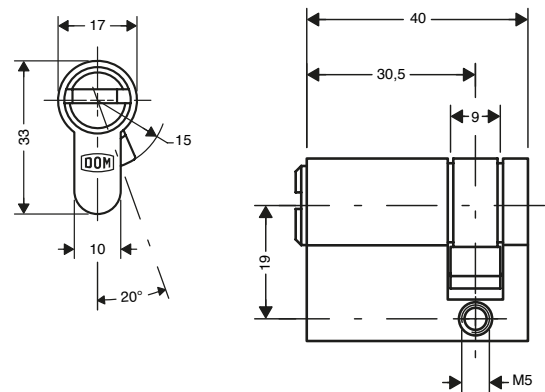

Key

- key thickness: 2,6 mm
- nickel silver reversible key: corrosion-free and low-wear
- high operating comfort due to reversible key
- new key head design
- special high-low milling (lift-out and sloped areas) for optimal key insertion
- with additional stamped recess
- complex coding in the key makes it difficult to make a duplicate key (very high key copy protection)
- key blade length adapted to all common safety fittings
- no key blanks available on the market

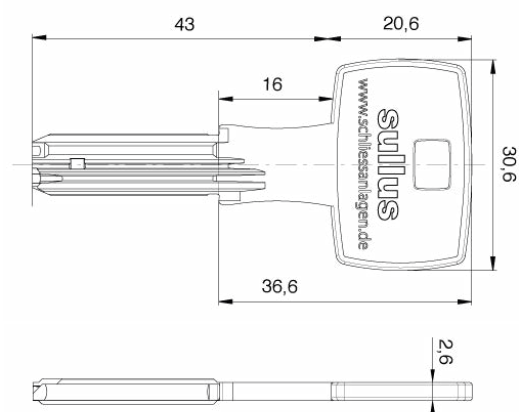

Technical details

Reversible key with special high-low milling (HT)

The DOM System ix Teco® (7TE) has a patented high-low milling in the key and thus offers a high technical key copy protection and high manipulation protection against opening techniques.



Impact protection

The cylinder contains impact protection pins and other safety elements that prevent access by impact keys to turn the inner pins.

Unlocking protection

The cylinder contains specially shaped unlocking security pins that prevent opening with the help of a lock pick.

Pulling protection

The cylinder contains a special cylinder core which prevents the cylinder from being pulled out by drilling into the core.

Security options

Increased drilling and core pulling protection (on request)

The cylinder is provided with increased drilling and core pulling protection by means of carbide pins arranged in several planes in the cylinder body and cylinder core.

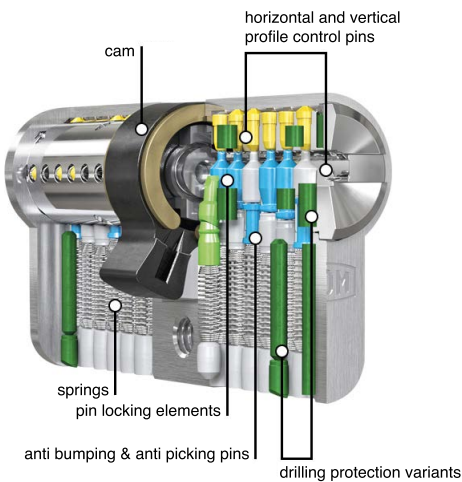

* this selection extends the delivery time ** on request