

The DORMAKABA penta system is a very flexible system and meets the highest security requirements both in the private sector and for large and complex installations. DORMAKABA penta offers a high level of security thanks to the sophisticated technology within the locking cylinder. This is achieved by 5 radial pin rows with up to 22 pin positions. High-quality materials such as low-wear chrome nickel steel for the pins and nickel silver for the key are also decisive. DORMAKABA penta locking cylinders are among the most secure on the market and protect against the most common opening methods. DORMAKABA penta locking cylinders are part of an ergonomically correct reversible key system, which means that the DORMAKABA reversible key is inserted vertically into the cylinder channel.

Basic length

- from 30/30 mm, measured from the middle of cam
- extension 5 mm per side
- The knob is always located on the inside of the cylinder.

Technical characteristics

- technical and patent copy protection offer high key copy protection
- 5 radially arranged rows of hardened steel pins
- up to 22 pin pairs per cylinder side in several rows on 85 possible positions
- number of possible, theoretical individual blocks: 867 trillion
- spring-loaded pairs of locking elements made of hardened steel, chemically nickel plated
- standard drilling protection (hardened steel locking elements and a 4 mm thick fixing screw made of hardened steel additionally on each cylinder side in the cylinder body)
- very high security against picking and the impact method
- classic door cylinder in 17 mm Euro profile, core diameter: 15 mm
- modular system design
- tested according to DIN EN 1303:2015 locking security class 6, and in conjunction with pull-out protection rosettes or fittings the attack resistance class 2, in optional lamella design the cylinders also fulfil attack resistance class D according to DIN EN 1303 without protective fittings
- certifications: DIN 18252-82 | Kitemark
- other cylinder shapes: e.g. swiss round profile, oval profile
- patent protection until 2033

Execution

- ergonomically correct reversible key (vertical key insertion)
- easy key insertion due to new design of the locking elements
- cylinder body: nickel plated brass
- integration into electronic DORMAKABA locking systems with LEGIC clip possible at any time (retrofitable), mechanical lock remains unchanged
- can be combined with DORMAKABA evolvo mechatronic locking system

Options / Special equipment

- different cylinder finishes
- pulling protection LAM, increased drilling protection BS2, pulling protection LAM with drilling protection
- different knob designs (mega knob, D-line knob)
- weather protection
- long bow with and without key clip

Operational area

- interior doors, exterior doors, front doors, apartment doors
- private houses and apartments, small and medium-sized enterprises
- industrial and administrative buildings, large and complex locking systems
- public facilities such as schools or community buildings

Scope of delivery

- knob cylinder incl. 3 or more keys
- 1 fixing screw M5 x 85 mm
- Security card

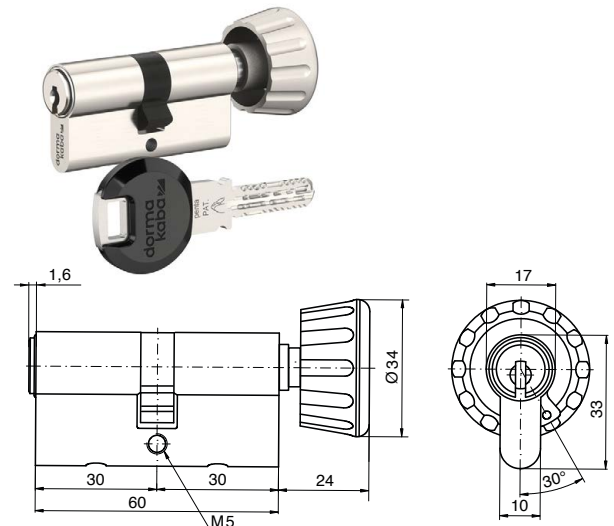

Key

- reversible key made of high-quality nickel silver, low-wear
- reversible key that is technically difficult to copy
- the new coding on the tip of the key cannot be produced with conventional key cutting machines; if the coding is missing, a key cannot be inserted or turned
- high breaking resistance
- 3 different key types, standard key: smartkey (optional largekey, long bow)
- colour clip standard: black (selectable from 12 colours)
- new exclusive colour clips only for the DORMAKABA penta system: in elaborate 2-component plastic technology with glossy surface

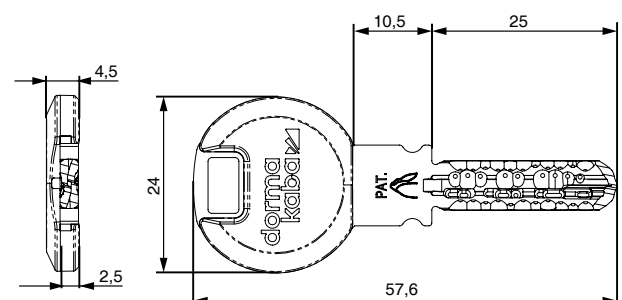

Technical details

Reversible key that is technically difficult to copy

The reversible key is technically difficult to copy. The keys are not coded by drilling, but by a special milling process that conceals the position of the coding on the key. The key is made of nickel silver and is highly resistant to breaking, has excellent sliding properties and lowest wear. New design of the locking elements allow the key to slide even more easily into the key channel.

High security against picking and the impact method

With the rapido method, conventional locking cylinders can be opened - without leaving any traces - with a specially made key and a hammer. The DORMAKABA penta system is protected against this.

DORMAKABA modular

The DORMAKABA modular system allows cylinders to be converted to other lengths or even other cylinder shapes on site with little effort. The locking system remains intact. The inserted cylinder cores (inserts) can easily be used in other cylinder designs (half cylinders, knob cylinders, camlock cylinders, etc.).

Standard drilling protection

The standard drilling protection is achieved by standard hardened steel locking elements and a hardened insert fixing screw (A).

This design complies with DIN EN 1303 attack resistance class B.

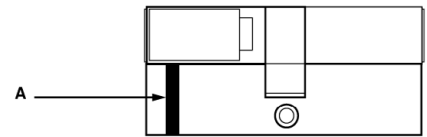

Pulling protection LAM

- optional version LAM - cylinder with own pulling protection incl. hardened locking elements
- design corresponds to DIN EN 1303 attack resistance class D

A = two insert fixing screws hardened

B = bible screws

C = steel lamellas

D = case for lamellas

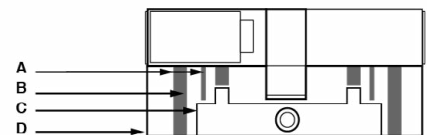

Increased drilling protection BS2

By using additional steel elements in the body and insert, a higher resistance to drilling is achieved. This option does not include an integrated pull-out protection. In combination with a tested core protection fitting, attack resistance class D is achieved.

A = insert with two carbide length pins = BS

B = tungsten carbide stud

C = short insert fixing screw hardened at the front

D = long insert fixing screw hardened at the rear

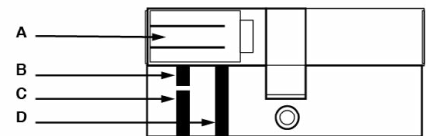

Pulling protection LAM with drilling protection

By using additional steel elements in the body and insert, a higher resistance to drilling is achieved. The increased pulling protection values are achieved by means of a pulling protection pin. The new dormaDORMAKABA VdS cylinder protects against pulling even in tubular frame doors. These cylinders can be used without protective fittings and achieve attack resistance class D without a tested core protection fitting.

A = insert with carbide pins = BS

B = tungsten carbide stud

C = bible screw

D = insert fixing screw hardened

E = steel lamella

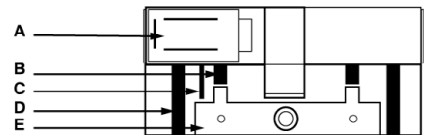

Largekey (clip and long bow)

- long key bow with extended key neck
- colour clip standard: black (selectable from 12 colors)
- when using e.g. protective fittings with core pulling protection rosette

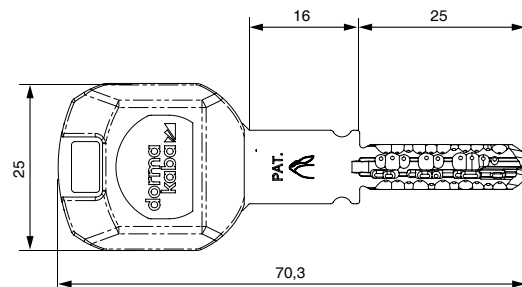

Long bow (armour bow)

- reversible key with armour bow
- when using e.g. security fittings with core pulling protection rosette and multiple locking systems

